

PLP

**POWERUP
LAWNCARE PRODUCTS**

HT24

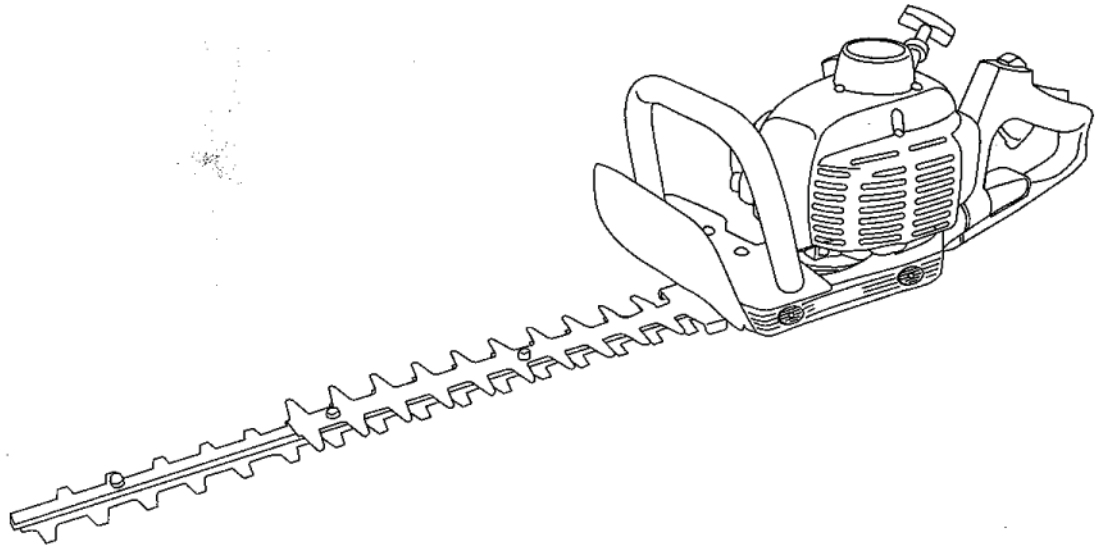

Owner's/Operator's Manual

Completely read and understand this manual before using this product.

FOREWORD

This Owner's/Operator's Manual is designed to familiarize the operator with the various features and component parts of the equipment and to assist you with the operation and maintenance of your new Hedge Trimmer.

It is essential that any operator of this Hedge Trimmer product reads and understands the contents of this manual before using the Hedge Trimmer.

Important safety instructions will be identified by the following safety symbol:



Failure to comply with the instructions in this manual may result in serious injury or death. For additional assistance, contact any local authorized PLP dealer.

TABLE OF CONTENTS

Foreword	1	Before operation	7
Specifications	1	Starting and stopping procedure	10
Product description	2	Carburetor adjustment	11
Marking	3	Operating the Power Hedge Trimmer	11
Symbol Explanation	3	Regular maintenance	12
Safety instructions	4	Storage	14

SPECIFICATION

Model	HT24
Dimensions L×W×H	1030×240×215mm
Dry Weight	5.2kg
Blade Length	600mm
Rear Handle	Rotational
Insulation System	Double insulation system (Metal springs and plastic dumpers)
Engine Model	HE230
Engine Displacement	22.5cm ³
Fuel Tank Capacity	0.4 ℓ
Carburetor	Walbro Diaphragm Type
Ignition System	Solid State
Spark Plug:	
Make	NGK
Type	BPMR6Y
Electrode Gap	0.6~0.7mm
Fuel Mixture:	Use only non-leaded regular gasoline. 2-Cycle oil mix 25:1 ratio must be approved for air-cooled engines.
Sound Pressure Level (Max.rpm)	83dB(A)
Vibration Level	
Front Handle	4m/s ²
Rear Handle	7m/s ²
(9300rpm:racing)	

PRODUCT DESCRIPTION

MODEL:HT24

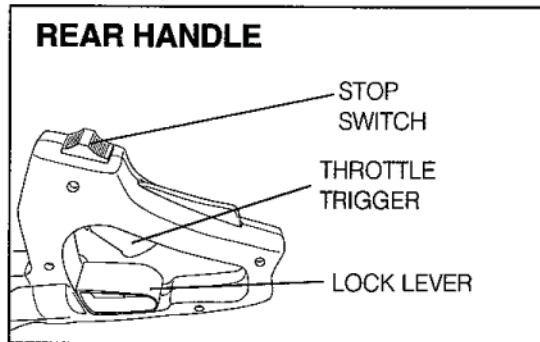
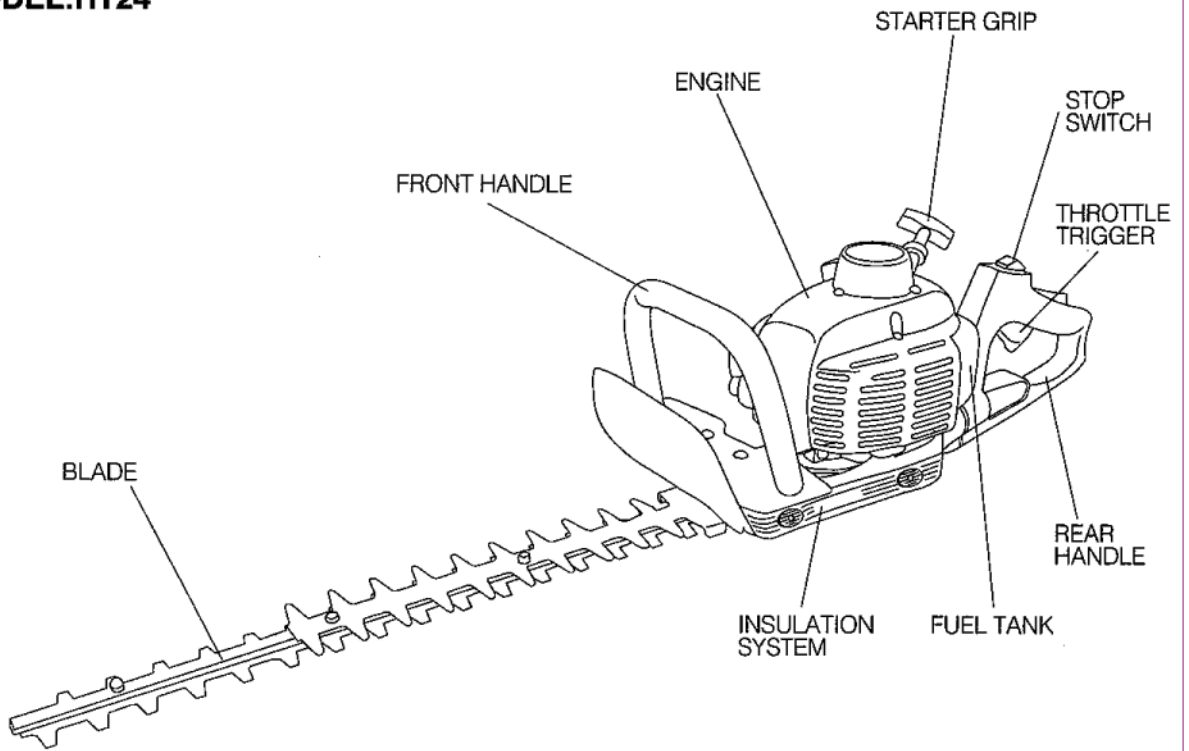

MARKING

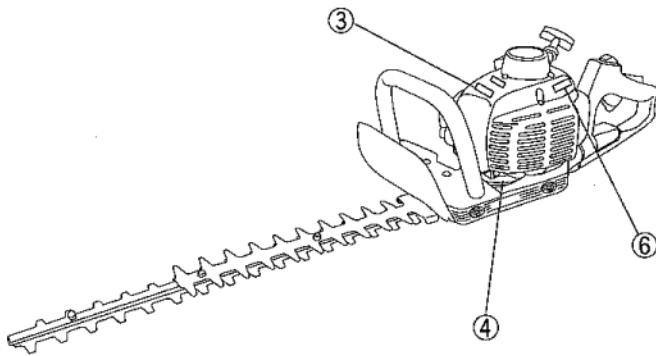

① MODEL NAME

② SERIAL No. (STAMPED)

③



See SYMBOL EXPLANATION

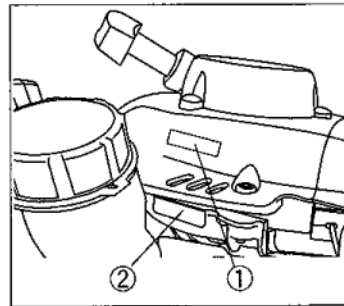
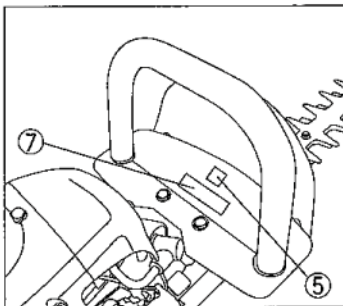

④



See SYMBOL EXPLANATION

⑤ SOUND PRESSURE LEVEL

⑥ C-Tick

⑦ Lubricate 15H

SYMBOL EXPLANATION



Read and understand this Owner's/Operator's Manual before using this product.



Fire Danger: Gasoline is highly flammable. Never add fuel to the Hedge Trimmer with a running or hot engine. Do not smoke or place any sources of heat in the vicinity of the fuel.



Breathing exhaust fumes can cause death. Never start or run the engine inside a close room or building.



Hot Surface Warning: Contact may cause burns. During use and for some time after stopping the engine, the engine and the gearcase are very hot. Do not touch engine components such as a cylinder, muffler and engine covers and gearcase until the engine has cooled to ambient temperature.

Always use:



- A protective helmet.
- Ear protection.
- Protective glasses or visor.



SAFETY INSTRUCTIONS



Operator safety

1. Read and understand this Owner's/Operator's Manual before using this product. Be thoroughly familiar with the proper use of this product.
2. Always wear eye protection.
3. Wear hearing protection.
4. Always wear heavy long pants, boots and gloves. Do not wear loose clothing, jewelry, short pants, sandals or go barefoot. Secure hair so it is above shoulder length.



5. Never operate this Hedge Trimmer when you are tired, ill, under the influence of alcohol, drugs or medication.
6. Never start or run the engine inside a closed room or building. Breathing exhaust fumes can cause death.

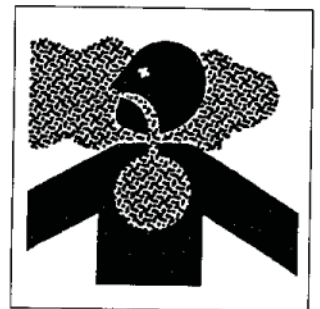

7. Keep handles clean of oil, fuel and dirt.

Power Hedge Trimmer safety

1. Shut off the engine and wait until the cutting blades have completely stopped moving before checking, maintenance or working on the Hedge Trimmer.
2. Inspect the Hedge Trimmer before each use. Replace damaged parts. Check for fuel leaks. Make sure all fasteners are in place and tightened securely. Follow the maintenance instructions provided on page 12 to 14 of this manual.
3. Inspect the Hedge Trimmer cutting blades and guide. Replace any parts that are cracked, chipped, or damaged before using the Power Hedge Trimmer.
4. Never use replacement parts that are not approved by PLP.
5. Maintain the Hedge Trimmer in accordance with the recommended maintenance intervals and procedures in the maintenance section, pages 12 to 14.
6. If running problems or excessive vibration occur, stop immediately and inspect the unit for the cause. If the cause cannot be determined or is beyond your ability to correct, return the Hedge Trimmer to your servicing dealer for repair.
7. Never use the hedge trimmer if handles are damaged or handle fasteners are loose. Always make sure all fasteners (nuts and bolts) are installed and properly tightened.
8. Never use a machine that has been modified so that it no longer corresponds with the original design.
9. Do not attempt to repair the Hedge Trimmer unless you are qualified to do so.
10. When transporting or storing the Hedge Trimmer always fit the blade shield.

Fuel safety

1. Gasoline is highly flammable and must be handled and stored carefully. Use a container approved for storing gasoline and/or fuel/oil mixture.
2. Mix and pour fuel outdoors and where there are no sparks or flames.
3. Do not smoke near fuel or the Hedge Trimmer or while using the Hedge Trimmer.
4. Do not overfill the fuel tank. Stop filling 10 ~ 20 mm from the top of the tank.
5. Wipe up any spilled fuel before starting the engine.

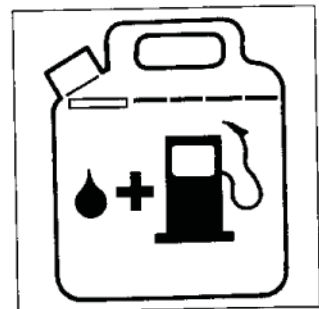

6. Move the Hedge Trimmer at least 3 m away from the fueling location before starting the engine.
7. Do not remove the Hedge Trimmer fuel tank cap while the engine is running or immediately after stopping the engine.
8. Allow the engine to cool before refueling.
9. Empty the fuel tank before storing the Hedge Trimmer. Fuel should be emptied after each use. Fuel left in the tank may leak during storage.
10. Store fuel and Hedge Trimmer away from open flame, sparks and excessive heat. Make sure fuel vapors cannot reach sparks or open flames from water heaters, furnaces, electric motors, etc.

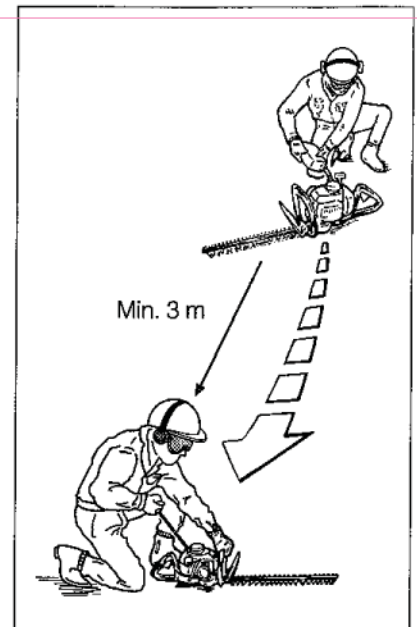

Power Hedge Trimmer operating safety

1. **THIS HEDGE TRIMMER CAN CAUSE SERIOUS INJURIES.**
Read the instructions carefully. Be familiar with all controls and the proper use of the Hedge Trimmer.
2. Never allow children to operate the Hedge Trimmer. It is not a toy.
3. Keep the area of operation clear of all persons, particularly small children and pets.
4. The Hedge Trimmer blades are extremely sharp. Do not put hands or feet near or under any moving parts. Keep body clear at all times.
5. Use the Hedge Trimmer only in daylight or good artificial light.
6. Inspect your work area before you begin. Remove string, rope or similar materials which can become entangled in the Hedge Trimmer blades.
7. Avoid hidden hazards. Watch for hidden objects within your working area, such as chain link fencing, cables, wires, telephone and power lines.
8. Never operate the Hedge Trimmer without proper guards or other protective safety devices in place.
9. Keep a firm footing and balance. Do not over-reach. Do not operate the Hedge Trimmer while standing on a ladder or similar temporary support.
10. Use the right tool for the job. Do not use the Hedge Trimmer for any job that is not recommended by the manufacturer.
11. While operating the Hedge Trimmer be always sure of a safe and secure operating position. Do not over reach.
12. To reduce fire hazard keep engine and silencer free of debris, leaves, and dry materials. Always wipe away spilled fuel and excessive lubricant before starting.

13. Always use two hands to operate the Hedge Trimmer.
14. Always be aware of your surroundings and stay alert for possible hazards that you may not hear due to the noise of the machine.
15. Know how to stop the machine quickly in an emergency. (See to stop the engine in STARTING AND STOPPING PROCEDURE SECTION.)

BEFORE OPERATION

FUELING

WARNING! The following precautions will lessen the risk of fire.

1. Do not smoke near fuel.
2. Mix and pour fuel outdoors and where there are no sparks or flames.
3. Always shut off the engine before refueling. Never remove the Hedge Trimmer fuel tank cap while the engine is running or immediately after stopping the engine.
4. Always open the fuel tank cap slowly to release any possible pressure inside the tank.
5. Do not overfill the fuel tank. Stop filling 10 ~ 20 mm from the top of the tank.
6. Tighten the tank fuel cap carefully but firmly after refilling.
7. Wipe up any spilled fuel before starting the engine.
8. Move the Hedge Trimmer at least 3 m away from the fueling location and fuel storage container before starting the engine.

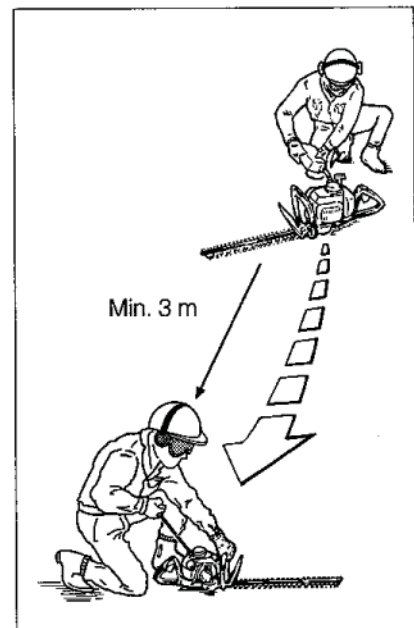

FUEL; MIXING GASOLINE AND OIL

WARNING! The engine used on this Hedge Trimmer is of a 2-cycle design. The internal moving parts of the engine, i.e., crankshaft bearings, piston pin bearings and piston to cylinder wall contact surfaces, require oil mixed with the gasoline for lubrication. Failure to add oil to the gasoline or failure to mix oil with the gasoline at the appropriate ratio will cause major engine damage which will void your warranty. For your fuel premix, only use a quality oil designed for 2-cycle air-cooled engine.

FUEL MIXTURE: Always use a good quality 2-cycle, air-cooled engine oil mixed at a ratio of 25:1.

FUEL MIXTURE CHART:

2-Cycle Oil (25:1)		
With	1 liter gasoline mix	40 ml oil
	2 liter	80 ml
	5 liter	200 ml

MIXING INSTRUCTIONS: Always mix fuel and oil in a clean container approved for gasoline. Mark the container to identify it as fuel mix for the Hedge Trimmer. Use regular unleaded gasoline and fill the container with half the required amount of gasoline. Pour the correct amount of oil into the container then add the remaining amount of gasoline. Close the container tightly and shake it momentarily to evenly mix the oil and the gasoline before filling the fuel tank on the Hedge Trimmer.

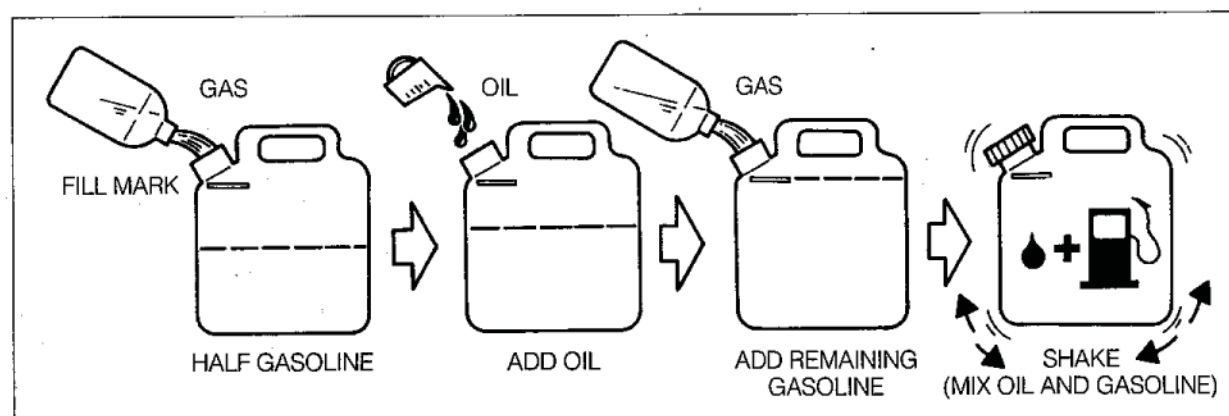

When refilling the Hedge Trimmer fuel tank, clean around the fuel tank cap to prevent dirt and debris for entering the tank during cap removal. Always shake the premix fuel container momentarily before filling the fuel tank.

Always use a spout or funnel when fueling to reduce fuel spillage. Only fill the tank to within 10 ~ 20 mm from the top of the tank. Avoid filling to the top of the tank filler neck.

NOTE:

1. Never mix gasoline and oil directly in the Hedge Trimmer fuel tank.
2. Do not use National Marine Manufacturer's Association (NMMA) or BIA certified oils. This type of 2-cycle engine oil does not have the proper additives for air-cooled, 2-cycle engines and can cause engine damages.

3. Do not use automotive motor oil. This type of oil does not have the proper additives for air-cooled, 2-cycle engines and can cause engine damage.

ADJUSTING THE CUTTING BLADES



CAUTION—DO NOT TOUCH THE SHARPENED EDGES OF THE CUTTING BLADES. THE CUTTING BLADES ARE EXTREMELY SHARP AND DANGEROUS AT ALL TIMES. ALWAYS WEAR GLOVES TO HELP PROTECT YOUR HANDS AND FINGERS FROM INJURY.

Before operating the Hedge Trimmer it is necessary to check the adjustment of the cutting blades. Blades that are too loose may vibrate, and will not provide a clean, smooth cut.



CAUTION—BLADES THAT ARE TOO TIGHT CAN CAUSE OVERLOADING WHICH MAY DAMAGE THE EQUIPMENT.

To adjust the cutting blades, refer to the illustration and locate the screws.

Loosen the nuts.

Gently turn the screws in until snug, then turn the screws back out one-fourth to a half. While holding the screws in place, tighten the nuts. Liberally coat the cutting blades with light oil. Start the engine and operate the Hedge Trimmer at full speed for at least one minute. Stop the engine, and when the blades are motionless, touch the blades with your hand.

The blades should be warm, but if they are too hot to touch, loosen the screws another 1/8 turn.

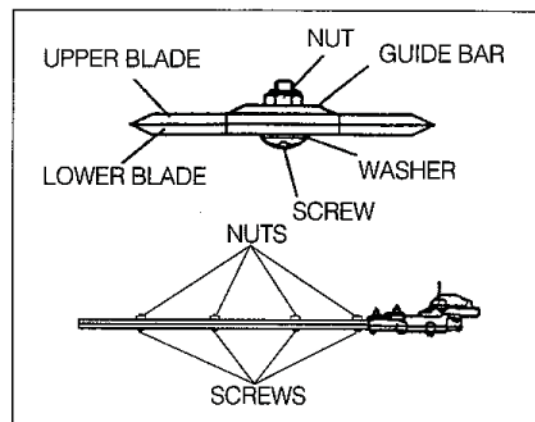

ROTATIONAL REAR HANDLE

Rear handle is adjustable to five different positions by pulling the lock lever and turn the rear handle. Pull the lock lever directly in line with the handle (following the arrow in fig), then turn the rear handle. It is extremely important that the handle is completely located and correctly locked in the selected position.

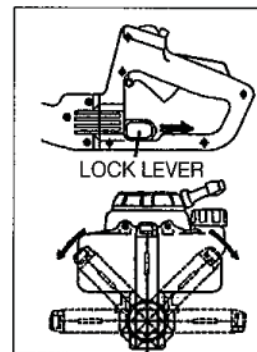

**Do not adjust the rear handle to any other position than specified five positions.
(Throttle lever does not work when the rear handle is unlocked)**



**Stop the engine before change the rear handle position.
Make sure the rear handle is locked before start the engine.**



During operation, hold the rear handle with upright regardless the blade direction.



Select the proper handle position to be always sure of a safe and secure operating position.

STARTING AND STOPPING PROCEDURE

Before Starting The Engine: Fill the fuel tank as instructed in the BEFORE OPERATION section of this manual. Rest the Hedge Trimmer on the ground. Make sure that the cutting blades are clear of branches, shrubs, debris, etc. Keep all bystanders, children and animals away from the working area.

STARTING THE ENGINE(for the carburetor with primer bulb)

The carburetors on PLP engines contain a choke system and are designed to start at IDLE speed.

1. Push and release the fuel primer bulb located on the bottom of the carburetor until air bubble free fuel is seen flowing through the clear fuel return hose back to the fuel tank.

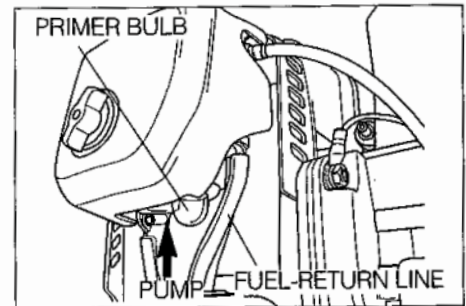

2. Move the choke lever to the closed position "Σ". When the engine is warm, move the choke lever to the open position "⊢".

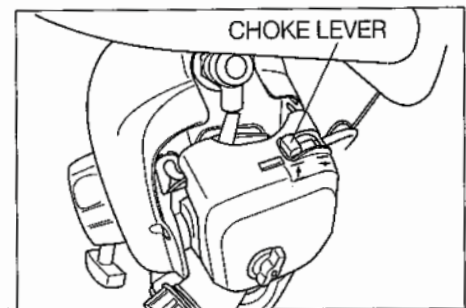

3. Set the engine stop switch to the "ON (|)" position. The throttle trigger positioned at IDLE.

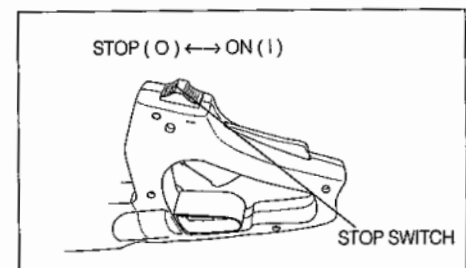

4. Grasp the starter grip and slowly pull the starter cord out until you feel some resistance, then pull the cord quickly and powerfully. Pull the starter grip until the engine starts. After the engine is started, move the choke lever to the open position.
5. After starting, allow the engine to run a few minutes to warm it up before using.

NOTE:

1. Do not pull the starter cord out completely.
2. Do not release the starter cord from the fully extended position.
3. Do not start the engine without rear handle locked.

To Stop The Engine:

1. Release the throttle trigger.
2. Slide the stop switch to the "STOP (O)" position.

CARBURETOR ADJUSTMENT

This Hedge Trimmer is equipped with non-adjustable fuel mixture carburetor. The engine idle speed is the only adjustment to the Operator.

The cutting blades may be moving during idle speed adjustment. Wear the recommended personal protective equipment and observe all safety instructions. Keep hands and body away from blade area.

Engine Idle Speed:

When the throttle trigger is released the engine should return to an idle speed which is 2700 ~3300 rpm or just below clutch engagement speed. The cutting blades must not move and the engine should not stall (stop running) at engine idle speed.

The engine idle speed is adjusted by rotating the idle speed screw on the carburetor. Turning the idle speed screw in (clockwise) increases engine speed while turning the screw out decreases engine speed.

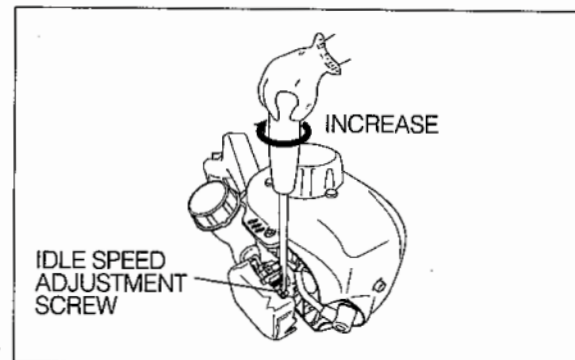

If idle speed adjustment is necessary and after adjustment the cutting blades move or the engine stalls, **stop using the Hedge Trimmer immediately!**

Contact your local authorized PLP Dealer for assistance and servicing.

OPERATING THE POWER HEDGE TRIMMER



CAUTION—Read the *SAFETY INSTRUCTIONS* on page (4) concerning the proper use of the Hedge Trimmer.

The PLP Hedge Trimmers is designed for cutting and trimming foliage and small branches up to 5 mm in diameter. Although the PLP Hedge Trimmer is capable of cutting larger diameter branches, wear and tear of the machine would be proportionally increased.



CAUTION—Always wear gloves and protective clothing when operating the Hedge Trimmer.

If the cutting blades become jammed, stop the engine immediately. Make certain all moving parts have stopped and disconnect the spark plug before inspecting the equipment for damage. Never use a Power Hedge Trimmer that has chipped, cracked, or broken cutting blades.

REGULAR MAINTENANCE

AIR FILTER

Maintenance Interval: The air filter should be cleaned daily or more often when working in extremely dusty conditions and replaced after every 100 hours of operation.

Maintenance: Loosen the knob and remove the air cleaner cover. Remove the foam filter. Clean the filter with warm, soapy water. Let the filter completely dry. Lightly apply SAE 30 motor oil to the foam filter and squeeze out all excess oil. Reassemble the filter and air cleaner cover.

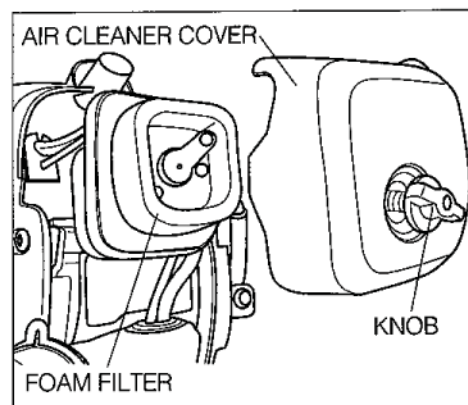

FUEL FILTER

Maintenance Interval: The fuel filter should be replaced after every 100 hours of operation.

Maintenance: The fuel filter is attached to the end of the fuel pick-up hose inside the fuel tank. To replace the fuel filter, first make sure the fuel tank is empty. Remove the fuel cap. Using a wire hook, gently pull the fuel filter out through the fuel filter opening. Grasp the fuel hose next to the fuel filter fitting and remove the filter **but do not release the hose**. While still holding on to the fuel hose, attach the new fuel filter. Drop the fuel filter back into the fuel tank. Make sure that the fuel filter is not stuck in a corner of the tank and that the fuel hose is not doubled over (kinked) before refueling.

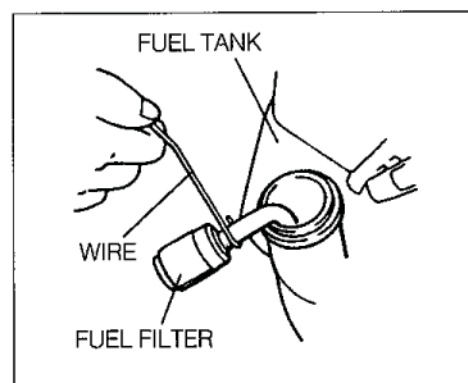

SPARK PLUG

Maintenance Interval: The spark plug should be removed from the engine and checked after each 25 hours of operation and replaced after every 100 hours of operation.

Maintenance: With the engine at ambient (room) temperature, loosen the cylinder cover screw and lift off the cylinder cover. (Refer to the illustration shown in the following **CYLINDER COOLING FINS** section.) Twist the high tension lead boot on the spark plug back and forth a couple of times to loosen boot then pull the boot off of the spark plug. Remove the spark plug. The electrodes can be cleaned with a stiff brush. Adjust the electrode air gap to 0.6–0.7 mm (0.024–0.028 in.). Replace the spark plug if it is oil-fouled, damaged or if the electrodes are worn down. **Do not overtighten the spark plug when installing.** The tightening torque is 10.7–16.6Nm (95–148 in. lbs.). Reinstall the cylinder cover.

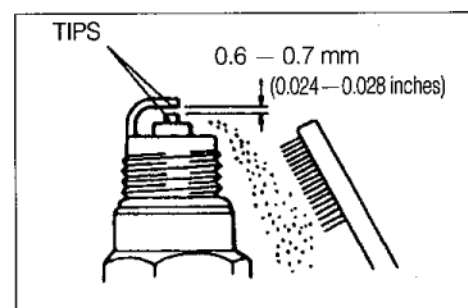

CYLINDER COOLING FINS

Maintenance Interval: The cylinder cooling fins should be cleaned after every 25 hours of operation or once a week whichever ever comes first. Air must flow freely around and through the cylinder cooling fins to prevent engine overheating. Leaves, grass, dirt and debris buildup on the fins will increase the operating temperature of the engine which can reduce engine performance and shorten engine life.

Maintenance: With the engine at ambient (room) temperature, loosen the cylinder cover screw (knob) and lift off the cylinder cover. Clean all dirt and debris from the cooling fins and from around the cylinder base. Reinstall the cylinder cover.

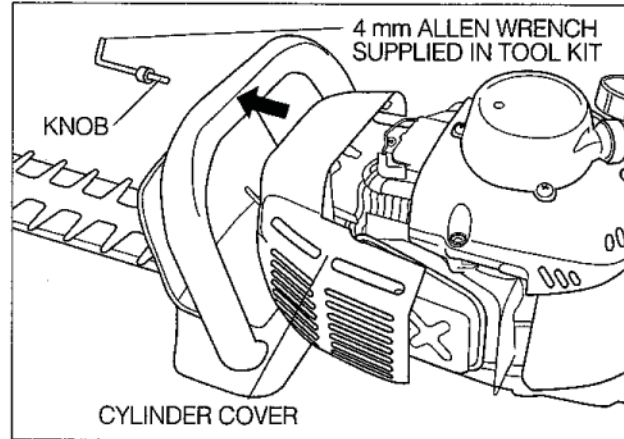

SPARK ARRESTER

Maintenance Interval: The spark arrester should be inspected and cleaned after every 25 hours of use. Replace the screen if it cannot be thoroughly cleaned or if it is damaged.

Maintenance: The spark arrester is installed inside the exhaust outlet of the muffler. One screw located on the side of the exhaust outlet holds the spark arrester in place. To remove the spark arrester, first remove the one screw retaining the cylinder cover, then remove the cylinder cover. Remove spark arrester retaining screw, then using a suitable pair of pliers, withdraw the spark arrester. Do not crush or distort the spark arrester flange during removal.

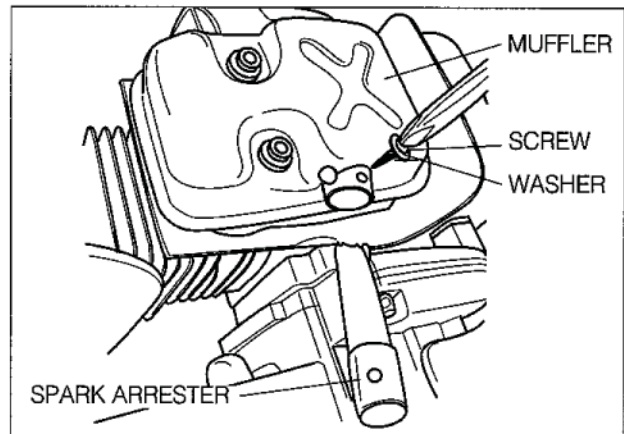

LUBRICATION : GEARCASE AND BLADES

The gearcase has a felt wick located at the blade opening. As the Hedge Trimmer is used, the grease within gearcase becomes very soft. The reciprocating blades constantly draw small amounts of grease between the blade contact surfaces for additional lubrication. If the gearcase is not lubricated at the recommended intervals, a gearcase failure will occur due to a lack of lubrication.

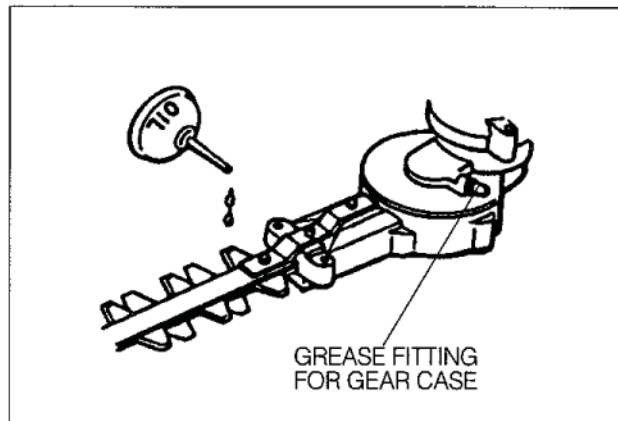

Gearcase failures due to improper maintenance are not covered by PLP warranty.

The gearcase and blades should be lubricated after each 10 hours of use.

NOTE: If the Hedge Trimmer is used under severe conditions such as high ambient temperatures (above 25°C) or for extended continuous periods of operation, the gearcase and blades must be lubricated every 2 hours.

Lubricate the gearcase at the grease fitting with a good quality #2 lithium-base grease. Lubricate the blades using a light (#10 wt.) oil.

GENERAL CLEANING AND TIGHTENING

The PLP Hedge Trimmer will provide maximum performance for many, many hours if it is maintained properly. Good maintenance includes regular checking of all fasteners for correct tightness, and cleaning of the entire machine. Pitch and gum deposits should be removed from the cutting blades daily. Adjustment of the cutting blade tension should be checked regularly. Refer to page (9) for instructions to adjust cutting blades.

STORAGE

For long-term storage of the Hedge Trimmer, empty the fuel tank into a suitable fuel storage container. Pump the primer bulb on the carburetor until all fuel is discharged through the clear fuel return hose. Run the engine to remove any fuel that may remain in the carburetor. Perform all regular maintenance procedures and any needed repairs. Remove the spark plug and squirt a very small amount of oil into the cylinder. Pull the starter cord once.

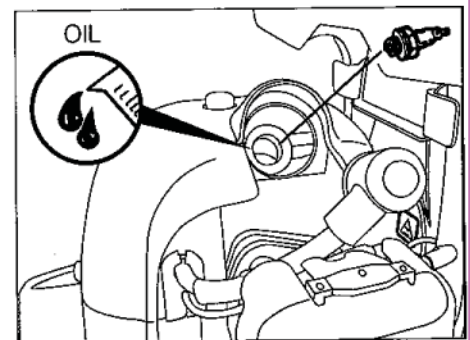

CAUTION: Oil may squirt out of the spark plug opening while pulling the starter cord. Protect your eyes and keep your face away from the spark plug opening. Slowly pull the starter cord to bring the piston to the top of the cylinder (TDC). Reinstall the spark plug. Liberally lubricated the blades with a light (#10 wt.) oil. Store the Hedge Trimmer in a dry place away from excessive heat, sparks or open flame.

PLP

**POWERUP
LAWNCARE PRODUCTS**

Free Post 5 Redcliffe Qld 4020