

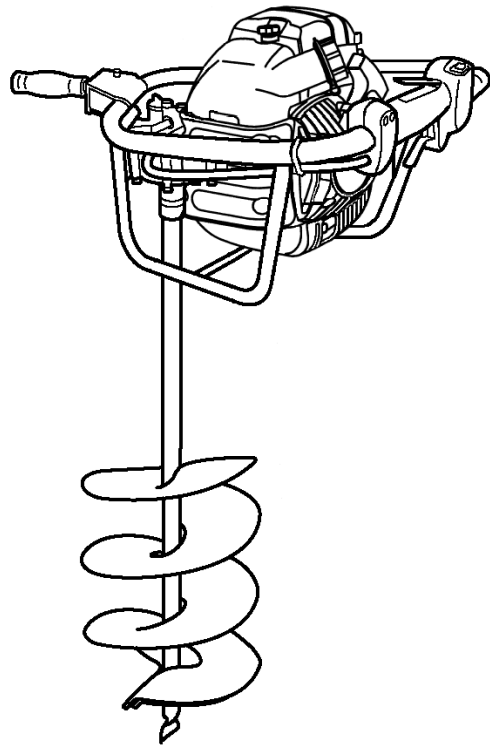

MARUYAMA

Earth Auger

MAG500RS



Owner's / Operator's Manual

Completely read and understand this manual before using this product.

Foreword

This Owner's/ Operator's Manual is designed to familiarize the operator with the various features and component parts of the equipment and to assist you with the assembly, operation and maintenance of your new Earth Auger.

It is essential that any operator of this Earth Auger reads and understands the contents this manual before using the Earth Auger.

For additional assistance, contact any local authorized MARUYAMA dealer.

Contents

	Page		Page
Foreword	1	Operation	11
Contents	1	Drilling	11
Product description	1	Maintenance	11
Safety instructions	2	Air filter	11
Operator safety	2	Fuel filter	11
Earth Auger safety	3	Spark plug	12
Fuel safety	3	Cylinder cooling fins	12
Earth Auger Operating safety	4	Spark arrester	13
Assembly	5	Drill	13
Installing left grip	5	Oil level	13
Installing drill	5	General cleaning and tightening	14
Adjusting throttle cable	5	Storage	14
Before operation	6	Troubleshooting	15
Oil and fuel	6	Specifications	15
Mixing gasoline and oil	7		
Starting and stopping	8		
Idle speed adjustment	10		

Product description

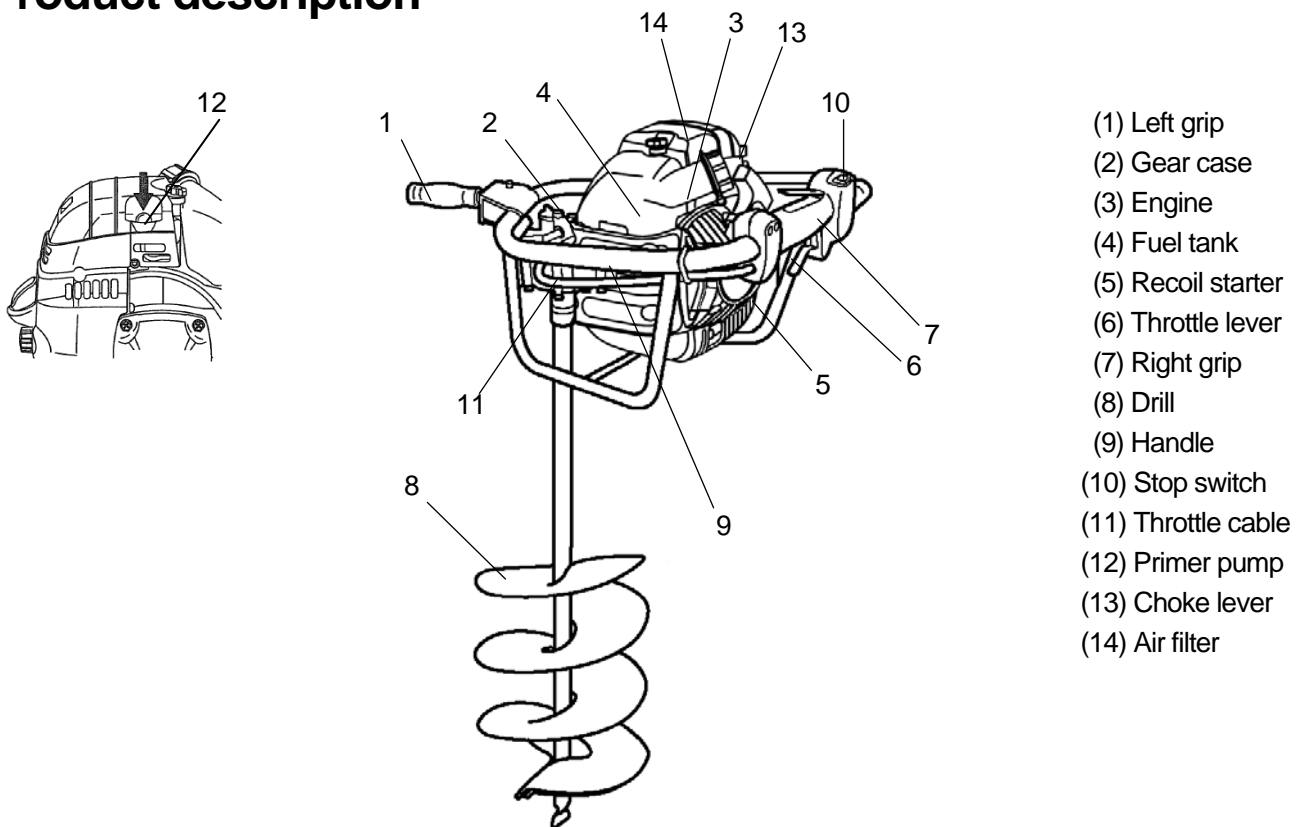

Safety decals



ON FRAME
(Part No. 229951)



ON ENGINE
(Part No. 267433)



ON ENGINE
(Part No. 283375)

Safety Decals are easily visible to the operator and are located near any area of potential danger. Replace any decal that is damaged or lost.

Safety Instructions

The warning system in this manual identifies potential hazards and has special safety messages that help you and others avoid personal injury, even death.

⚠ DANGER, **⚠ WARNING** and **⚠ CAUTION** are signal words to identify the level of hazard.

⚠ DANGER : signals an extreme hazard that will cause serious injury or death if the recommended precautions are not followed.

⚠ WARNING : signals a hazard that may cause serious injury or death if the recommended precautions are not followed.

⚠ CAUTION : signals a hazard that may cause minor or moderate injury if the recommended precautions are not followed. Two other words are also used to highlight information. “Important” calls attention to special mechanical information and “Note” emphasizes general information worthy of special attention.

Operator safety

1. Read and understand this Manual before using the Earth Auger.
Be thoroughly familiar with the proper use of this Earth Auger.
2. Always wear eye protection and hearing protection.
3. Always wear heavy long pants, a long sleeved shirt, boots and gloves. Do not wear loose clothing, jewelry, short pants, sandals, or go barefoot. Secure hair so it is above shoulder length.
4. Never operate this Earth Auger when you are tired, ill, or under the influence of alcohol, drugs or medication.
5. Never start or run the engine inside a closed room or building.
Breathing exhaust fumes can cause death.
6. Keep the grip of handles clean of oil, fuel and dirt.



Earth Auger safety

1. Shut off the engine and be certain the drill has completely stopped rotating before inverting the Earth Auger, performing maintenance on or working on the machine.
2. Make sure the Earth Auger is assembled correctly and that the drill is correctly installed and securely fastened as instructed in the Assembly section.
3. Inspect the Earth Auger before each use. Replace damaged parts. Check for fuel leaks. Make sure all fasteners are in place and tightened securely. Follow the maintenance instructions beginning on page 11.
4. Make sure the drill does not rotate at engine idle speed. Refer to Idle Speed Adjustment, page 10.
5. Inspect the drill and replace any parts that are cracked, chipped or damaged before using the Earth Auger.
6. Make sure the drill is installed and positioned correctly before using the Earth Auger.
7. Never use a drill or replacement parts that are not approved by MARUYAMA.
8. Maintain the Earth Auger according to the recommended maintenance intervals and procedures in the Maintenance section beginning on page 11.
9. If running problems or excessive vibration occur, stop immediately and inspect the unit for the cause. If the cause cannot be determined or is beyond your ability to correct, return the Earth Auger to your servicing MARUYAMA dealer for repair.

Fuel safety

1. Gasoline is highly flammable and must be handled and stored carefully. Use a container approved for fuel for storing gasoline and/or fuel/oil mixture.
2. Mix and pour fuel outdoors and where there are no sparks or flames.
3. Do not smoke near fuel or Earth Auger, or while using the Earth Auger.
4. Do not overfill the fuel tank. Stop filling 10mm from the top of the tank.
5. Wipe up any spilled fuel before starting the engine.
6. Move the Earth Auger at least 3m away from the fueling location before starting the engine.
7. Do not remove the Earth Auger fuel tank cap immediately after stopping the engine.
8. Allow the engine to cool before refueling.
9. Drain the tank and run the engine dry before storing the unit.
10. Store fuel and Earth Auger away from open flame, sparks and excessive heat. Make sure fuel vapors cannot reach sparks or open flames from water heaters, furnaces, electric motors, etc.

Earth Auger Operating safety

1. THIS EARTH AUGER CAN CAUSE SERIOUS INJURIES. Read the instructions carefully. Be familiar with all controls and the proper use of the Earth Auger.
2. Never allow children to operate the Earth Auger. It is not a toy. Never allow adults to operate the unit without first reading this Operator's Manual.
3. Avoid using the Earth Auger near rocks, gravel, stones and similar material that would cause harmful missiles.
4. Keep children, bystanders and animals outside a 15m radius from the operator and Earth Auger.
5. If you are approached while operating the Earth Auger, stop the engine and drill rotation.
6. Use the Earth Auger only in daylight or good artificial light.
7. Do not put hands or feet near or under any rotating parts. Keep clear at all times. Keep all parts of your body away from the rotating drill and hot surfaces such as the muffler.
8. Grip the handles firmly with both hands using your whole hand. Place your feet slightly apart (slightly further apart than the width of your shoulders) so that your weight is distributed evenly across both legs, and always be sure to maintain a steady, even posture while working.
9. Maintain the speed of the engine at the level required to perform drilling work, and never raise the speed of the engine above the level necessary.
10. Keep a firm footing and balance. Do not overreach.
11. Use the right tool for the job. Do not use the Earth Auger for any job that is not recommended by MARUYAMA.

Assembly

Installing left grip

Screw in the left grip to the bracket provided on the frame and tighten securely.

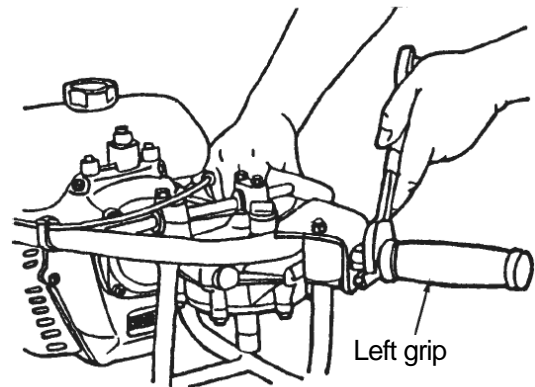

Installing drill

1. Slide the ring clip and remove the lock pin from the drill.
2. Put the drill onto the auger output shaft and insert the lock pin. Cover it with the ring clip.

- (1) PTO shaft
- (2) Clip band
- (3) Drill
- (4) Lock pin

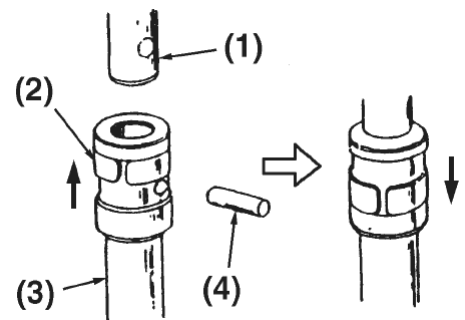

Adjusting throttle cable

The normal play is 1 or 2mm when measured at the carburetor side end. Readjust with the cable adjuster as required.

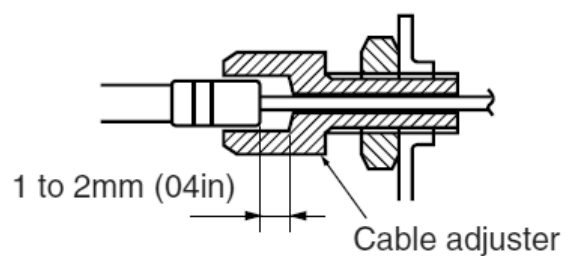

Before operation

Oil and fuel

1. Mix and pour fuel outdoors and where there are no sparks or flames.
2. Always shut off the engine before refueling. Never remove the Earth Auger fuel tank cap while the engine is running or immediately after stopping the engine.

WARNING

POTENTIAL HAZARD

- Gasoline contains gasses that can build up pressure inside a fuel tank.

WHAT CAN HAPPEN

- fuel can be sprayed on you when removing fuel tank cap.

HOW TO AVOID THE HAZARD

- Remove fuel tank cap slowly to avoid injury from fuel spray.

3. Always open the fuel tank cap slowly to release any possible pressure inside the tank.
4. Do not overfill the fuel tank. Stop filling 10mm from the top of the tank.
5. Tighten the fuel tank cap carefully but firmly after refilling.
6. Wipe up any spilled fuel before starting the engine.
7. Move the Earth Auger at least 3m (10ft.) away from the fueling location and fuel storage container before starting the engine.

DANGER

POTENTIAL HAZARD

- In certain conditions gasoline is extremely flammable and highly explosive.

WHAT CAN HAPPEN

- A fire or explosion from gasoline can burn you, others and cause property damage.

HOW TO AVOID THE HAZARD

- Use a funnel and fill the fuel tank outdoors, in an open area, when the engine is cold.
Wipe up any gasoline that spills.
- Do not fill the fuel tank completely. Add gasoline to the fuel tank until the level is 10mm below the bottom of the filler neck. This empty space in the tank allows gasoline to expand.
- Never smoke when handling gasoline, and stay away from an open flame with gasoline in an approved container and keep it out of the reach of children.
- Do not mix fuel for more than two month use.

Recommended oil type

Only use a two-cycle engine oil formulated for use in high-performance, air-cooled two-cycle engines.

IMPORTANT: Do not use two-cycle oil intended for water cooled outboard motors. This type of two-cycle engine oil does not have the additives for air-cooled two-cycle engines and can cause engine damage.

Do not use automotive motor oil. This type of oil does not have the proper additives for air-cooled two-cycle engines and can cause engine damage.

Recommended fuel type

Use clean, unleaded gasoline with an octane rating of 85 or higher. Use of unleaded gasoline results in fewer combustion chamber deposits and longer spark plug life. Use of premium grade fuel is not necessary or recommended.

IMPORTANT: Never use gasohol or alcohol blended fuels in this engine.

Mixing gasoline and oil

IMPORTANT: The engine used on this Earth Auger is of a two-cycle design. The internal moving parts of the engine, i.e., crankshaft bearings, piston pin bearings and piston to cylinder wall contact surfaces, require oil mixed with the gasoline for lubrication.

Failure to add oil to the gasoline or failure to mix oil with the gasoline at the appropriate ratio will cause major engine damage which will void your warranty.

Fuel mixture

The fuel: oil ratio is 25 parts gasoline to 1 part oil or 25:1.

Fuel mixture chart 25:1

Gasoline	two-cycle oil
1 litre	40 ml
2 litre	80 ml
5 litre	200 ml

Mixing instructions

IMPORTANT: Never mix gasoline and oil directly in the Earth Auger fuel tank.

1. Always mix fuel and oil in a clean container approved for gasoline.
2. Mark the container to identify it as fuel mix for the Earth Auger.
3. Use regular unleaded gasoline and fill the container with half the required amount of gasoline.
4. Pour the correct amount of oil into the container then add the remaining amount of gasoline.
5. Close the container tightly and shake it momentarily to evenly mix the oil and the gasoline before filling the tank on the Earth Auger.
6. When refilling the Earth Auger fuel tank, clean around the fuel tank cap to stop dirt and debris from entering the tank during cap removal.
7. Always shake the premix fuel container momentarily before filling the fuel tank.
8. Always use a spout or funnel when fueling to reduce fuel spillage.
9. Fill the tank only to within 10mm from the top of the tank. Avoid filling to the top of the tank filler neck.

Starting and stopping

The drill will start moving upon the engine starts.

Before starting the engine

1. Fill the fuel tank as instructed in the Before Operation section of this manual.
2. Rest the Earth Auger on the ground.
3. Make sure the drill is clear of any broken glass, nails, wire, rocks or other debris.
4. Keep all bystanders, children and animals away from the working area.

Cold starting procedure

The carburetor on this engine is equipped with a fuel primer and a choke system.

To start a “cold” engine properly, perform the following procedure:

1. Pump the primer bulb until fuel can be seen flowing through the fuel return line to the fuel tank. Flowing fuel should be almost clear, not foamy or full of bubbles.
2. Turn the choke lever to the close position.

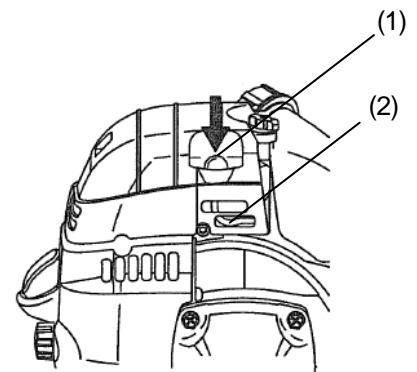

- (1) Primer Pump
- (2) Fuel Return Line

2. Turn the choke lever to the close position.

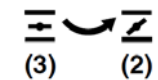
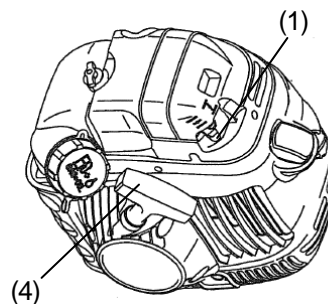

- (1) Choke lever
- (2) Close
- (3) Open
- (4) Starter grip

3. With the stop switch “RUN”, pull the starter grip .

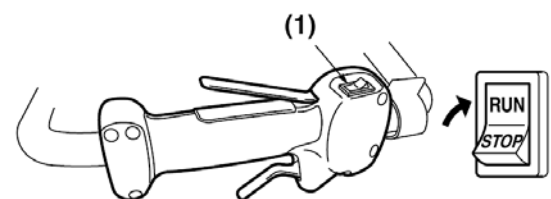

- (1) Stop Switch

4. While holding the unit firmly, pull out the starter grip quickly until engine started.

- (a) Hold the right grip with your left hand.
- (b) Support the left grip with your waist.
- (c) Do not press the drill on the ground.

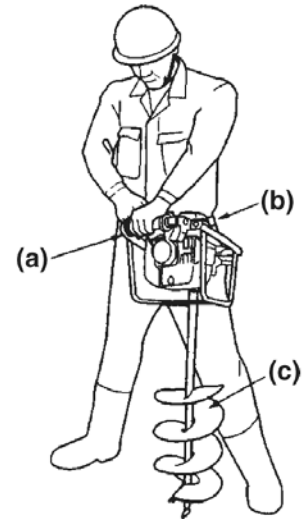

After the engine is started, turn the choke lever to the Open position.

If the engine stops running before you turn the choke lever to the open position :

Go ahead and open the choke, pull the starter grip quickly until engine started.

Hot restart

To start the engine that is already warmed up (hot restart).

1. Turn the choke lever to the open position, and shift the stop switch to the "RUN" position.
2. Leave the throttle trigger in the idle position and pull the starter grip.
3. If the engine fails to start after three to four pulls, follow the instructions in the Cold Starting Procedure section above.

If the engine fails to start after you follow the above procedures, contact an authorized MARUYAMA dealer.

To stop the engine

1. Release the throttle trigger.
2. Shift the stop switch to "STOP" position.

Idle speed adjustment

This Earth Auger is equipped with non-adjustable fuel mixture carburetor. The idle speed is the only adjustment for the operator.

WARNING

POTENTIAL HAZARD

- Engine must be running to make carburetor adjustments.
- When engine is running, attached tool and other parts are moving.

WHAT CAN HAPPEN

- Contact with moving attached tool or other moving parts could cause serious personal injury or death.

HOW TO AVOID THE HAZARD

- Keep hands, feet and clothing away from attached tool and other moving parts.
- Keep all bystanders and pets away from unit while making carburetor adjustments.

The drill may be moving during idle speed adjustment. Wear the recommended personal protective equipment and observe all safety instructions. Keep hands and body away from the drill.

When the throttle trigger is released, the engine should return to an idle speed. The correct speed is 2400 - 2800 min⁻¹ (or just below the clutch engagement speed).

The drill must not move and the engine should not stall (stop running) at engine idle speed.

To adjust the engine idle speed, rotate the idle speed adjustment screw on the carburetor.

- Turn the idle speed screw in (clockwise) to increase the engine idle speed.
- Turn the screw out (counterclockwise) to decrease the engine idle speed.

If idle speed adjustment is necessary, and after adjustment the drill rotates or the engine stalls, stop using the Earth Auger immediately!

Contact your local authorized MARUYAMA Dealer for assistance and servicing.

Idle Speed Adjustment Screw

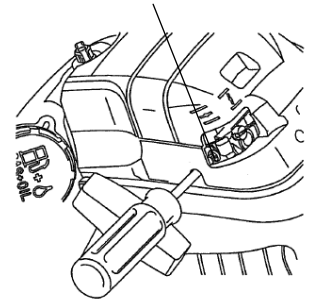

Operation

Drilling

- Keep a firm grip of the auger at all times on a wide stance and by holding the handle with both hands.
- A reacting motion may occur on the auger when spinning drill has hit on stones or tree roots under the ground. Always hold the auger securely to control such motion.
- Start drilling with half-throttle, and gradually increase the engine speed so that the drill may get into the ground smoothly.
- When the drill has been caught in the ground and cannot be pulled out, stop the engine and rotate the auger counter-clockwise.



Maintenance

Air filter

Maintenance interval

- The air filter should be cleaned **daily**, or more often when working in extremely dusty conditions.
- Replace after every 100 hours of operation.

Air filter cleaning

1. Remove the foam element.
2. Clean the foam element with warm, soapy water. Let the element dry completely.
3. Apply a light coat of SAE 30 motor oil to the foam element and squeeze out all excess oil.
4. Reassemble the foam element and filter cover.

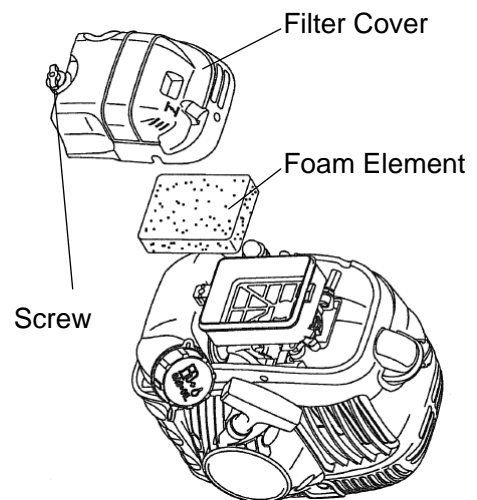

Fuel filter

Maintenance interval

The fuel filter should be replaced after every 100 hours of operation.

Fuel filter replacement

The fuel filter is attached to the end of the fuel pick-up hose inside the tank. To replace the fuel filter:

1. Make sure the fuel tank is empty.
2. Loosen the fuel tank cap.
3. Using a wire hook, gently pull the fuel filter out through the fuel filler opening.
4. Grasp the fuel hose next to the fuel filter fitting and remove the filter, but do not release the hose.
5. While still holding on to fuel hose, attach the new fuel filter.
6. Drop the new fuel filter back into the fuel tank.
7. Make sure that the fuel filter is not stuck in a corner of the tank, and that the fuel hose is not doubled over (kinked) before refueling.

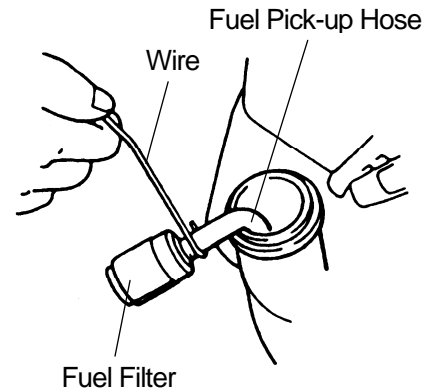

Spark plug

Maintenance interval

- The spark plug should be removed from the engine and checked after each 25 hours of operation.
- Replace the spark plug after every 100 hours of operation.

Spark plug maintenance

1. Twist the high tension lead boot on the spark plug back and forth a couple of times to loosen the boot, then pull the boot off of the spark plug.
2. Remove the spark plug.
3. Clean the electrodes with a stiff brush.
4. Adjust the electrode air gap to 0,6-0,7 mm.
5. Replace the spark plug if it is oil-fouled, damaged, or if the electrodes are worn down.
6. Do not over tighten the spark plug when installing.
The tightening torque is 10,7-16,6 N·m.

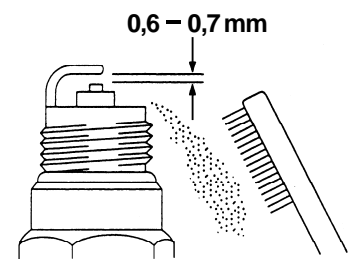

Cylinder cooling fins

Maintenance interval

- The cylinder cooling fins should be cleaned after every 25 hours of operation, or once a week, whichever comes first.
- Air must flow freely around and through the cylinder cooling fins to prevent engine overheating. Leaves, grass, dirt and debris buildup on the fins will increase the operating temperature of the engine, which can reduce engine performance and shorten engine life.

Cooling fin cleaning

1. Loosen the knob and lift off the cylinder cover.
2. Clean all dirt and debris from the cooling fins and from around the cylinder base.
3. Reinstall the cylinder cover.

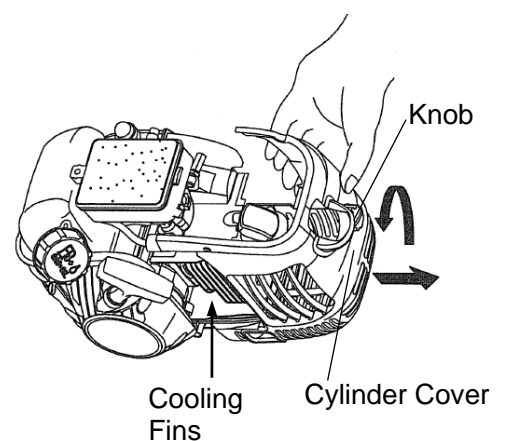

Spark Arrester

WARNING

POTENTIAL HAZARD

- Muffler surface becomes hot when Trimmer/Brushcutter is in operation and remains hot for sometime after the engine is shut off.

WHAT CAN HAPPEN

- Contact with hot muffler surface could cause a burn.

HOW TO AVOID THE HAZARD

- Make sure the muffler is cool before inspecting and cleaning the spark arrester.

Maintenance Interval

- The spark arrester should be inspected and cleaned after every 25 hours of operation. Replace the screen if it cannot be thoroughly cleaned or if it is damage.

Maintenance

- The spark arrester is installed inside the exhaust outlet of the muffler.

One screw and washer located on the side of the exhaust outlet holds the spark arrester in place.

1. Remove the cylinder cover. (See section “Cylinder Cooling Fins”)

2. Remove spark arrester retaining screw, then using a suitable pair of pliers, withdraw the spark arrester. Do not crush or distort the spark arrester flange during removal.

3. The screen can be cleaned using a non-flammable solvent and a stiff wire brush. To reinstall insert the spark arrester into the exhaust outlet while aligning the holes in the arrester flange and outlet for the retaining screw.

4. Reinstall the screw and washer, then reinstall the cylinder cover.

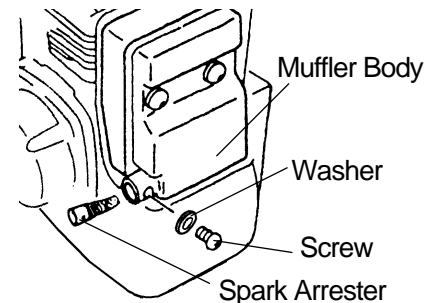

Drill

Make sure to use the sharp drill.

Replace if the bit or the tip is worn and the drill may not get into the object smoothly.

- Drill bigger than f40mm has bit
- Drill bigger than f60mm has tip

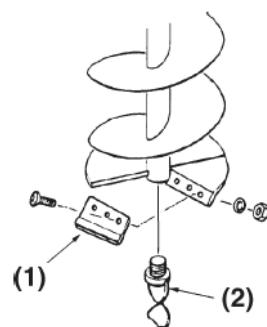

φ150 Drill

- (1) Tip
- (2) Bit

Oil level

Check oil level of the gear box every 50 hours of use and change with new oil as necessary. (SAE #80-90).

Recommended change interval

1st: After 50 hours of use

2nd and on: Every 100 hours of use.

- Disconnect the engine from the gear box and check the clutch condition every 100 hours of use. Wipe off oil attached to the drum and shoes, and replace parts with a new one if found to be worn.

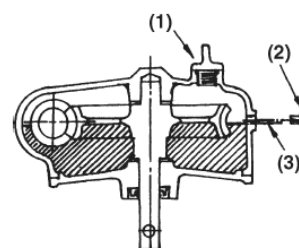

- (1) Oiling port
- (2) Oil drain port
- (3) Oil level

General cleaning and tightening

WARNING

POTENTIAL HAZARD

- When engine is running, attached tool and other parts are moving.

WHAT CAN HAPPEN

- Contact with moving tool or other moving parts could cause serious personal injury or death.

HOW TO AVOID THE HAZARD

- Always turn off your Earth Auger before you clean or perform any maintenance on it.

The MARUYAMA Earth Auger will provide maximum performance for many, many hours if it is maintained properly. Good maintenance includes regular checking of all fasteners for correct tightness, and cleaning the entire machine.

Storage

For long term storage of the Earth Auger:

1. Empty the fuel tank into a suitable fuel storage container.
2. Run the engine to remove any fuel that may remain in the carburetor.
3. Perform all regular maintenance procedures and any needed repairs.
4. Remove the spark plug and squirt a very small amount of engine oil into the cylinder.

CAUTION

POTENTIAL HAZARD

- Oil may squirt out of the spark plug opening when you pull the starter grip.

WHAT CAN HAPPEN

- Oil can cause eye injuries.

HOW TO AVOID THE HAZARD

- Protect your eyes and keep your face away from the spark plug opening.

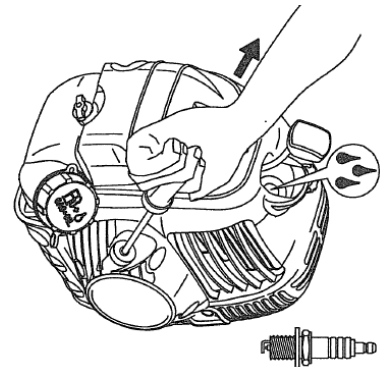

5. Pull the starter grip once.
6. Slowly pull the starter grip to bring the piston to the top of the cylinder (TDC).
7. Reinstall the spark plug.
8. Brush off dirt from the drill surface and apply rust protective oil.
9. Store the Earth Auger in a dry place away from excessive heat, sparks or open flame.

Troubleshooting

Problem	Cause	Action
Engine will not start	<ul style="list-style-type: none"> • Stip switch set to STOP position • Empty fuel tank • Primer bulb wasn't pushed enough • Engine flooded 	<ul style="list-style-type: none"> • Move switch to RUN position • Fill fuel tank • Press primer bulb until fuel flows • Use warm engine starting procedure
Engine will not Idle	<ul style="list-style-type: none"> • Idle speed set incorrectly 	<ul style="list-style-type: none"> • Set Idle speed
Engine lacks power or stalls when cutting	<ul style="list-style-type: none"> • Throttle wire has come loose • Dirty air filter 	<ul style="list-style-type: none"> • Tighten throttle wire • Clean or replace air filter

If further assistance is required, contact your local authorized **MARUYAMA** service dealer.

Specifications

	MAG500RS
Engine displacement, cm ³	49,9
Idling speed, min ⁻¹	2600
Spark plug	NGK BPMR6Y
Electrode gap, mm	0,6-0,7
Type of carburetor	Diaphragm
Fuel tank capacity, liters	1,0
Weight without fuel and drill , kg	10,2
Adaptable drill size Diameter, mm	40 to 200

Manufacturing:
Maruyama Mfg. Co., Inc. 4-15 Uchi-kanda 3-Chome,
 Chiyoda-ku Tokyo 101-0047 Japan
 Tel. 03-3252-2281