

OPERATOR'S MANUAL

OPTIONAL VACUUM KIT

Read and understand both this operator's manual and hand-held blower's manual before using this product.

WARNING

Stop the engine before installing or removing the vacuum kit.

Vacuum Kit Description

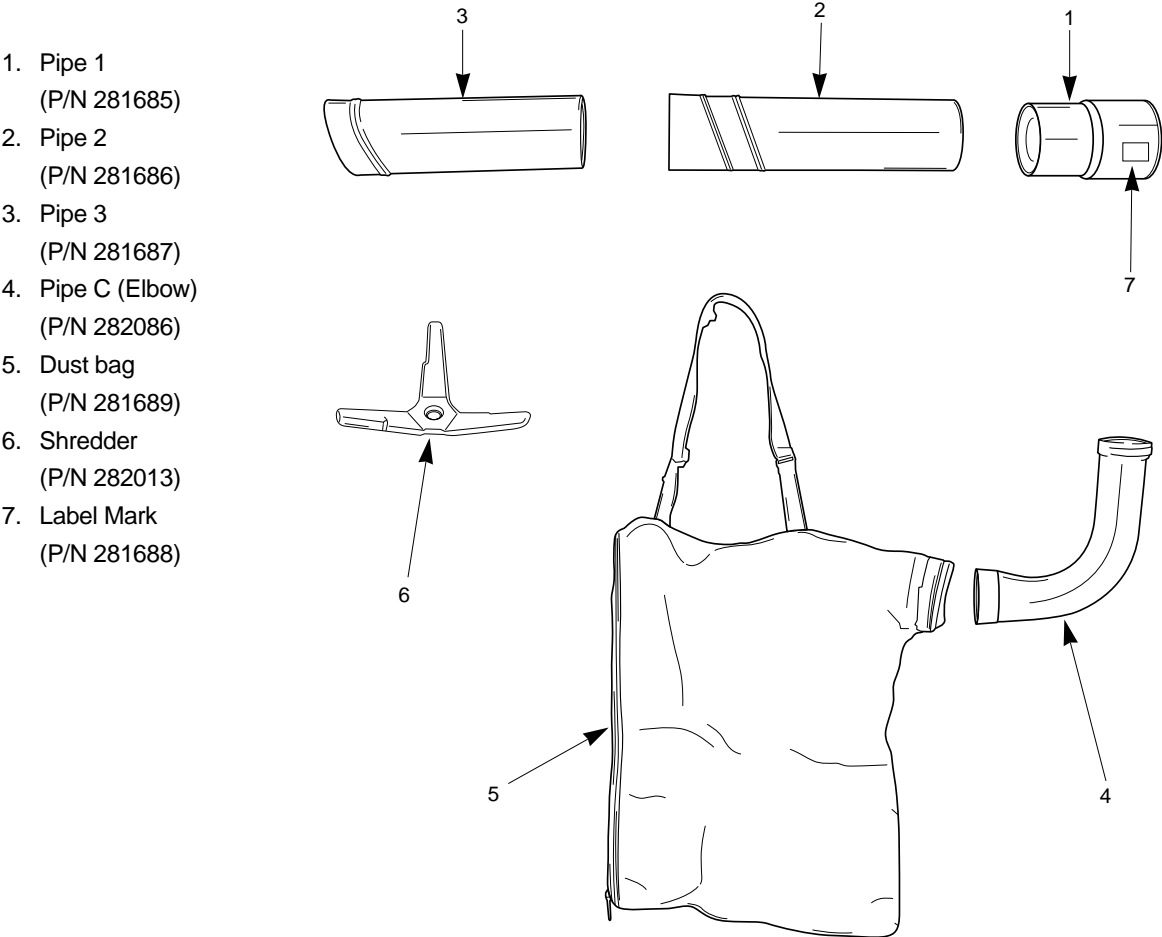

Assembly

1. Installing The Shredder

1. Remove the six screws retaining the fan cover, then remove the fan cover.

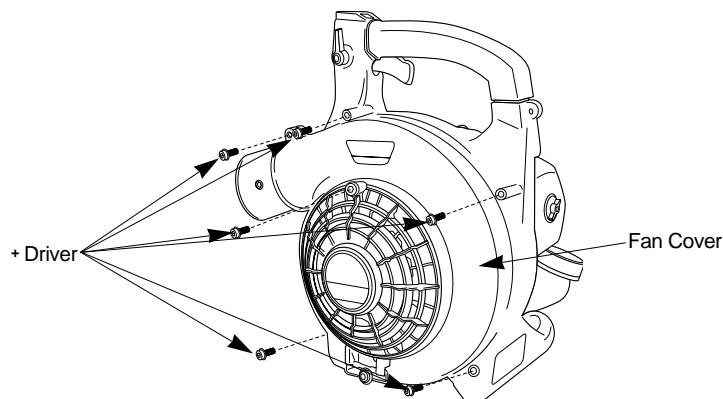

2. Remove the nut and the washer of the fan.

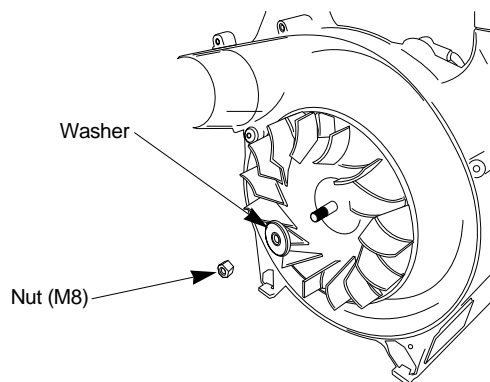

3. Install the shredder instead of the washer, then tighten the nut. The tightening torque is 69-104 in.lbs. (7.9-11.7 N.m).

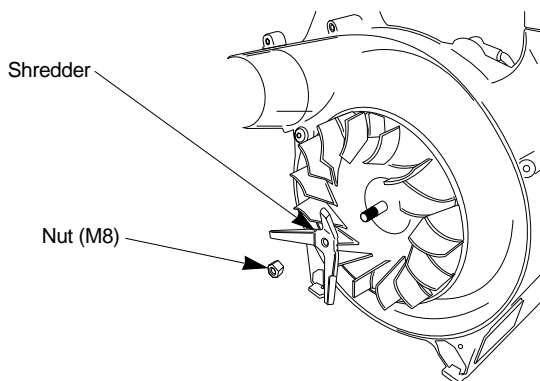



4. Reinstall the fan cover.

2. Installing The Vacuum Pipe

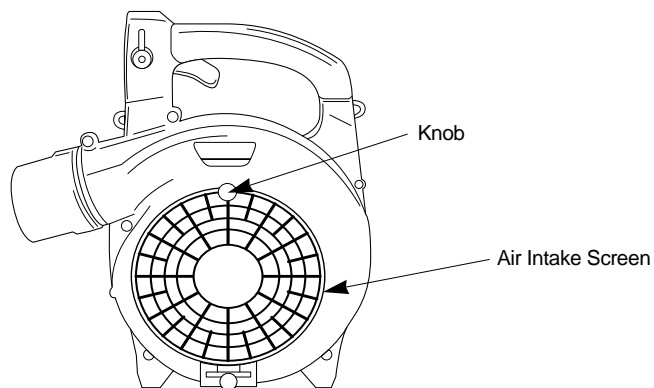
1. Loosen the knob, and open the air intake screen.



2. Align arrow mark of the pipe 1 and  mark of the blower. Then insert the pipe 1 into the blower until the bottom end of fan cover. Turn the pipe 1 until the arrow mark is aligned with  mark of the blower to the click fitting position.

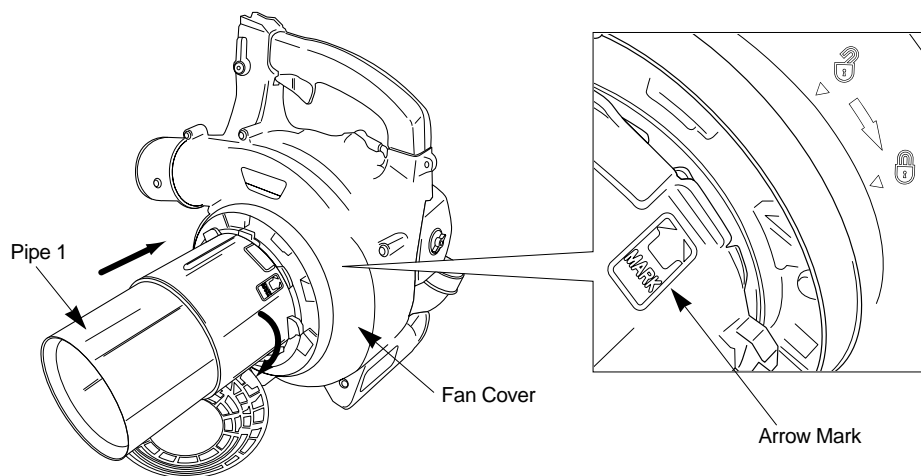

3. Insert pipe 2 to the pipe 1. insert pipe 3 to the pipe 2. Adjust the skew end face to ground.

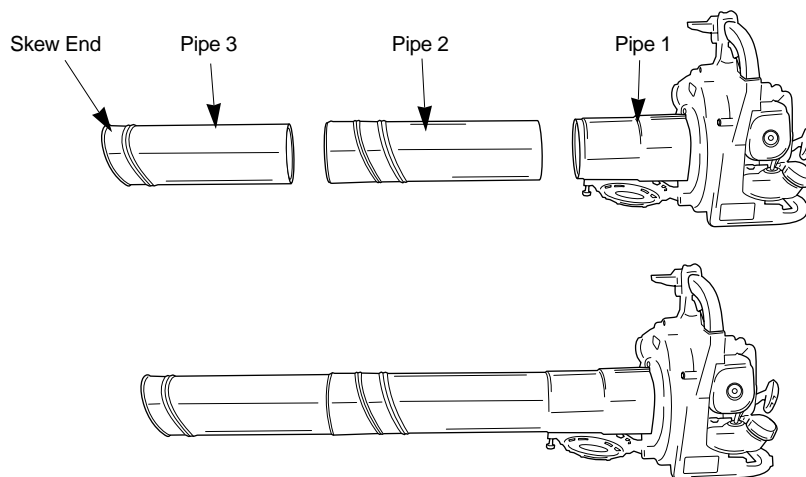

3. Installing Pipe C (Elbow) And Dust Bag

1. Open the fastener of the dust bag. Insert the pipe C from groove side into the dust bag.

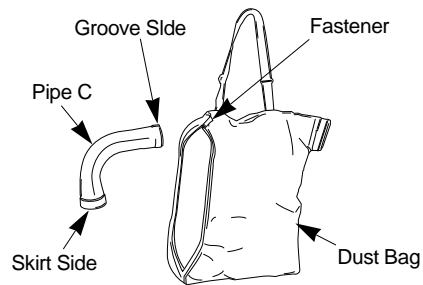

2. Push the pipe C until the skirt side locate to the dust bag opening. Secure the velcro strap.

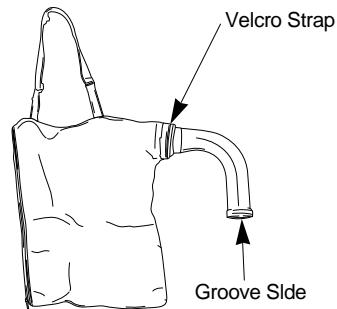

3. Close the dust bag fastener.

4. Align groove of the pipe C with pegs on blower housing. Place the dust bag to the vacuum pipe side. Then slide the pipe C onto the blower housing. Rotate the pipe C clockwise to lock it into place.

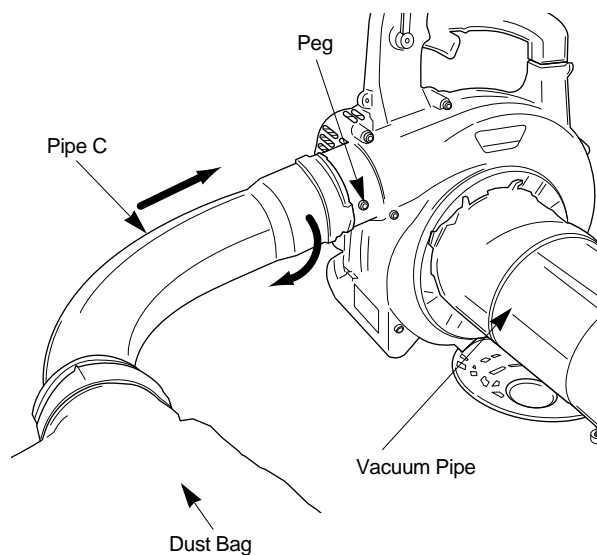

Operation

⚠ WARNING

Never vacuum in any liquid or lit cigarette. It can lead to an electric shock or burn.

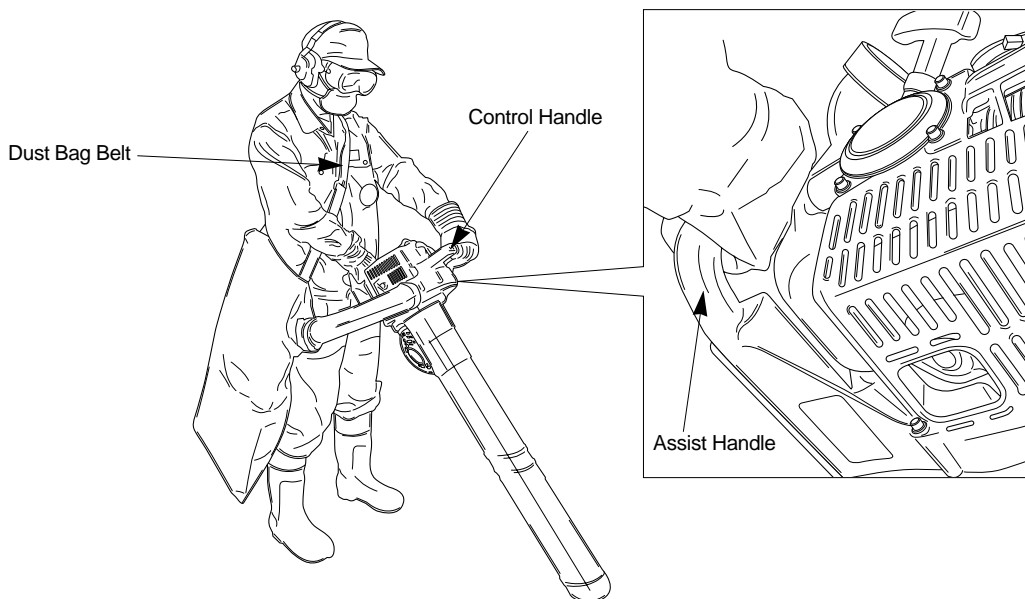

1. Put the dust bag belt on the shoulder, and adjust the length of the belt.
2. The vacuum kit is designed for two-handed operation. Operate the unit with your left hand on the control handle, and your right hand on the assist handle.
3. Check that the dust bag is not twisted.
4. Detach the dust bag from the unit when it is full of dust. Open the dust bag fastener to clear out the dust.

⚠ WARNING

Discharge dust from dust bag before it becomes too much. Too much dust will loose dust vacuuming capacity. It may cause spilt out the dust to the engine side, and cause catch fire.

Note :

1. Never vacuum large wood chips, metals, glasses, small stones, or other foreign materials.
2. Take particular caution when vacuum wet leaves. Wet leaves likely to stick to the fan. In case of wet leaves stuck, get rid of leaves from the fan.

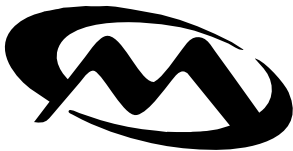

Maruyama U.S., Inc.

Post Office Box 309
Auburn, WA 98071-0309
253-735-7368 voice
253-735-1416 fax

www.maruyama-us.com
282776-00 05.12 TAP/M